

* empfohlener
Glaseinstand

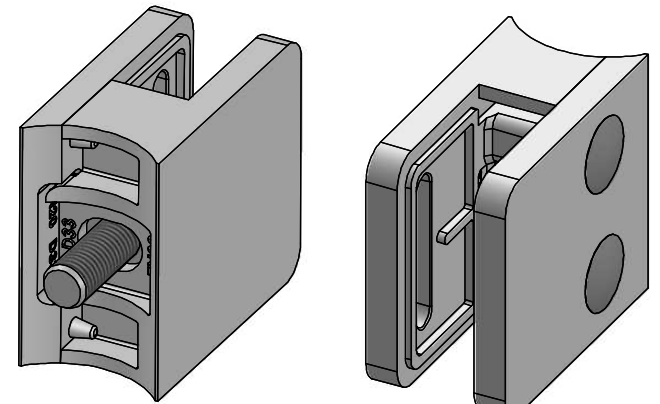

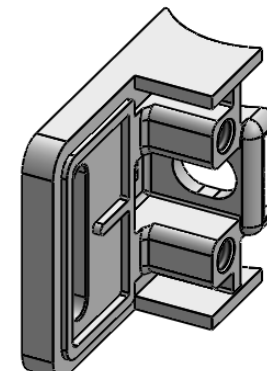

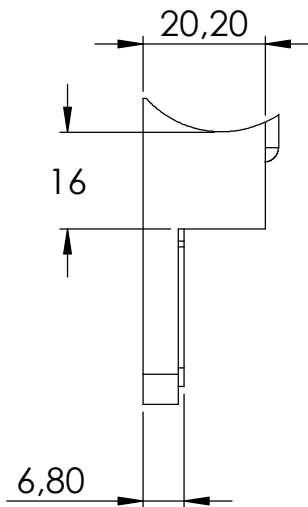

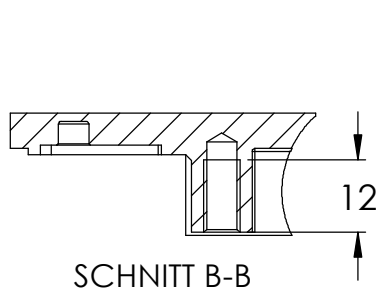
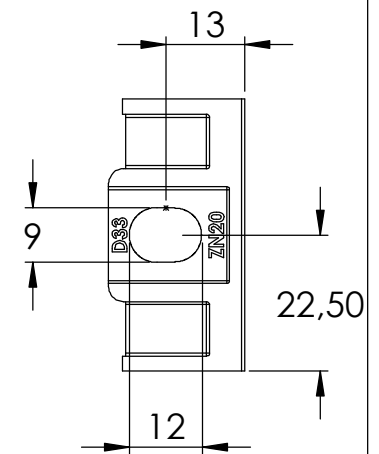
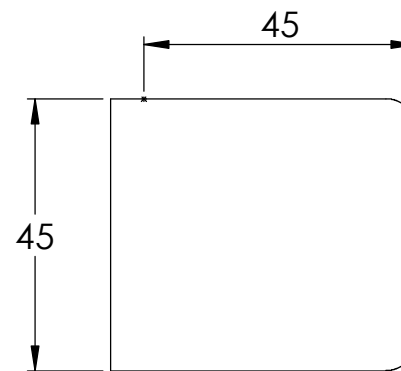
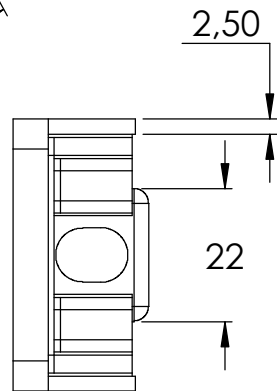
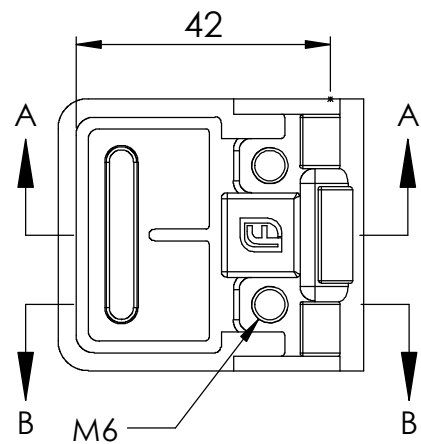
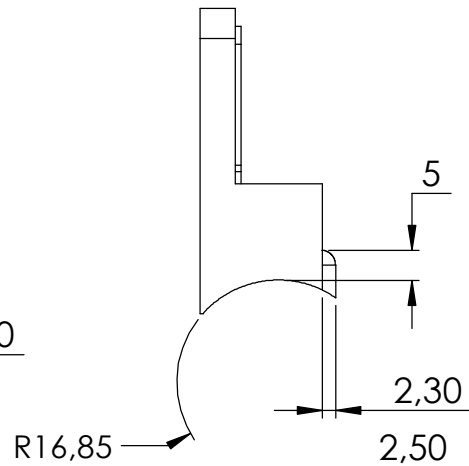
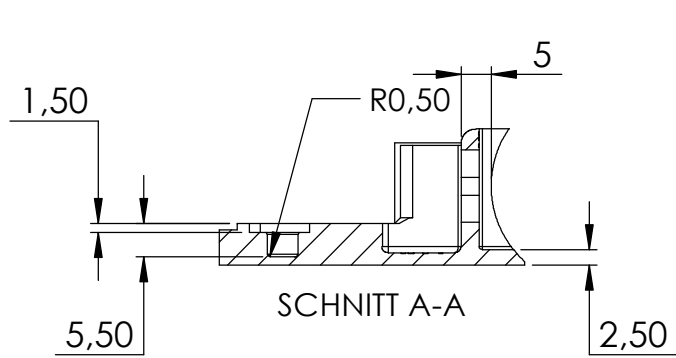
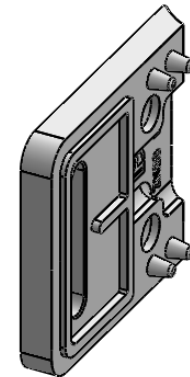
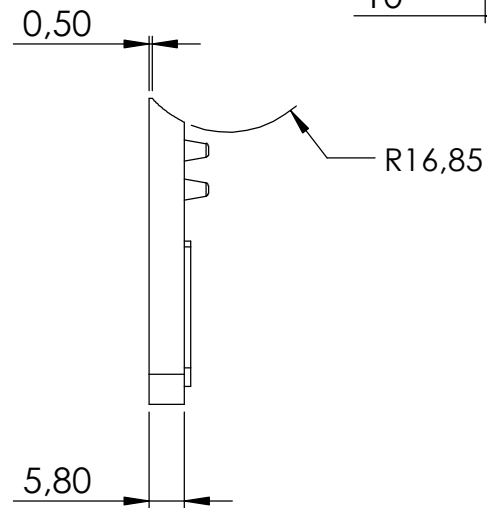
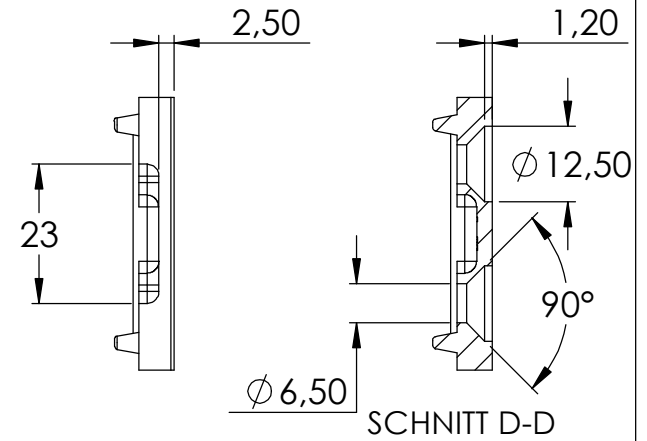
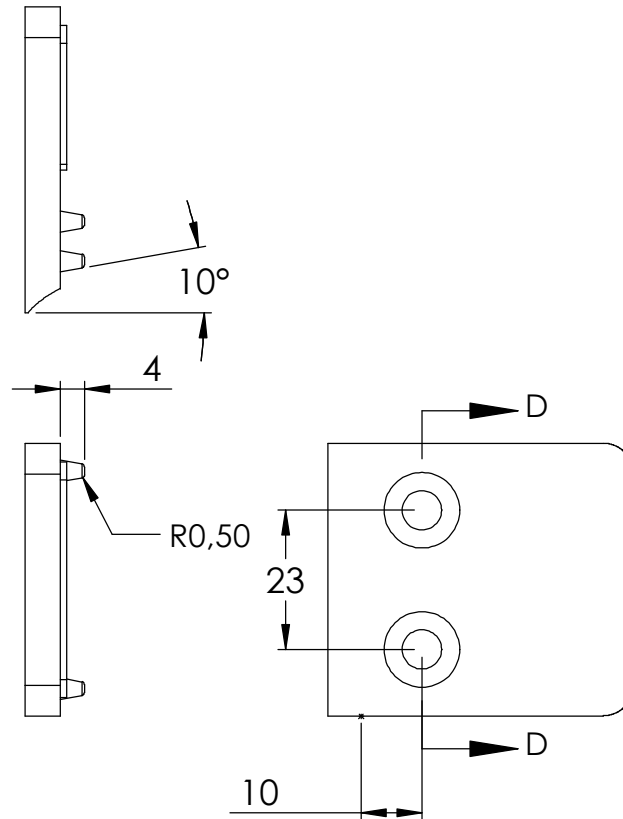
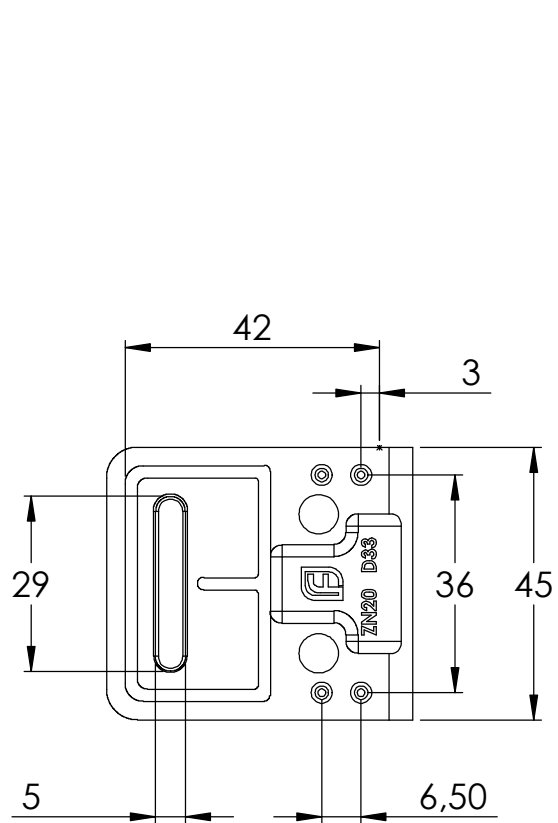
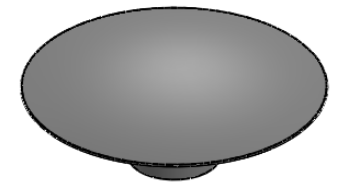
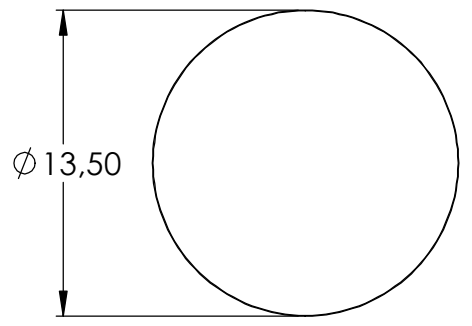
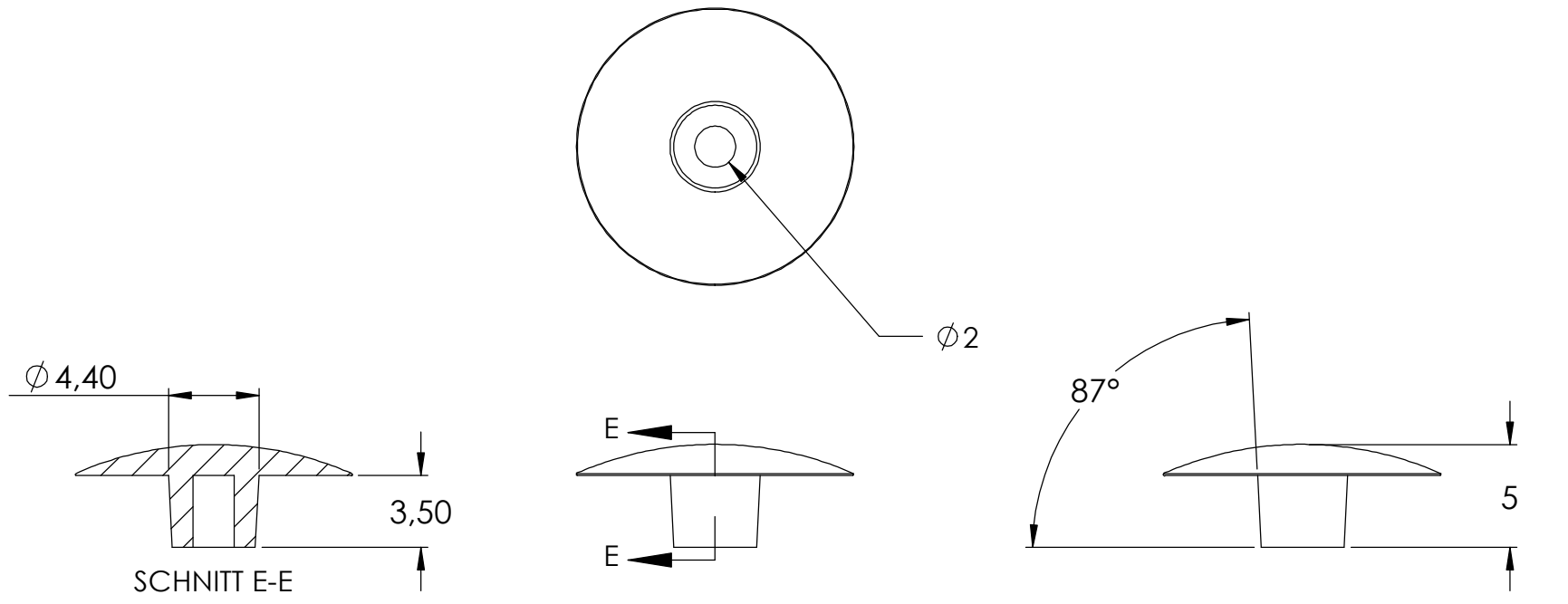

4	DIN 7991 M6x16	2
5	11xx-xxx Teil3	2

