

SCHNITT A-A

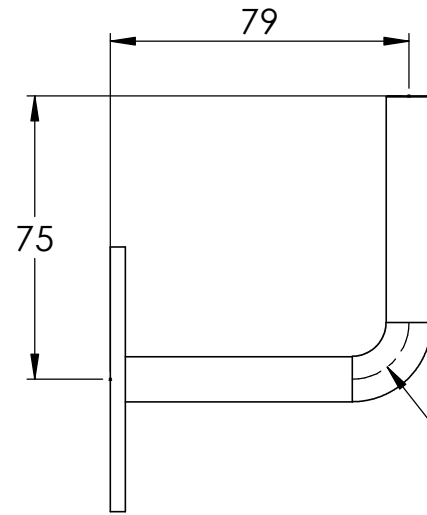

DIN 7991
M6x16

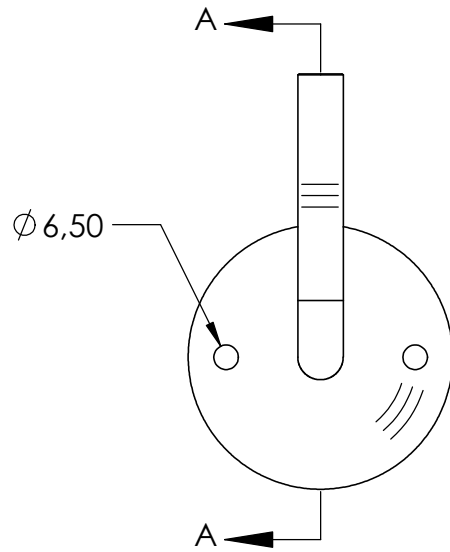

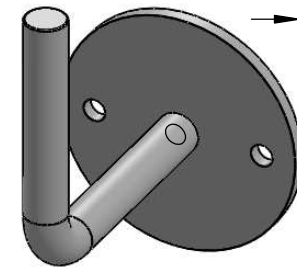
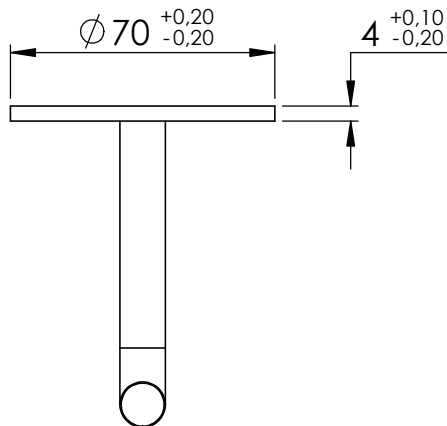
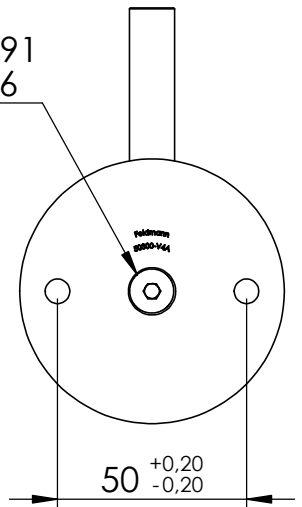
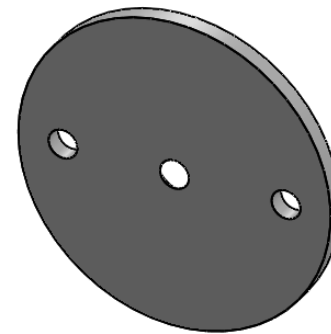
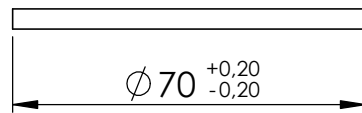
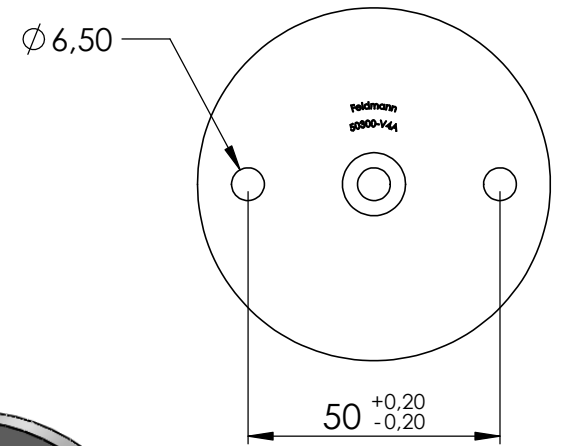
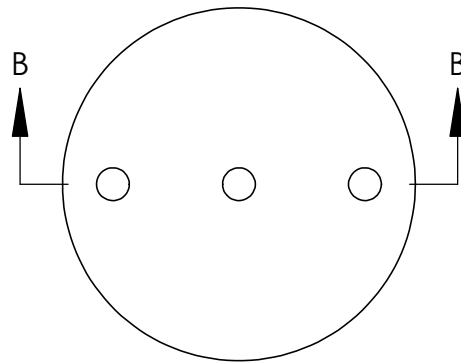
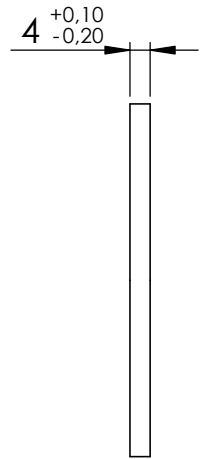
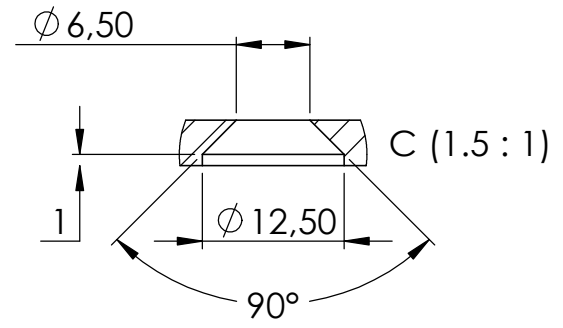
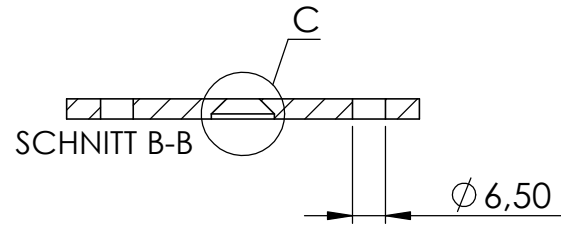

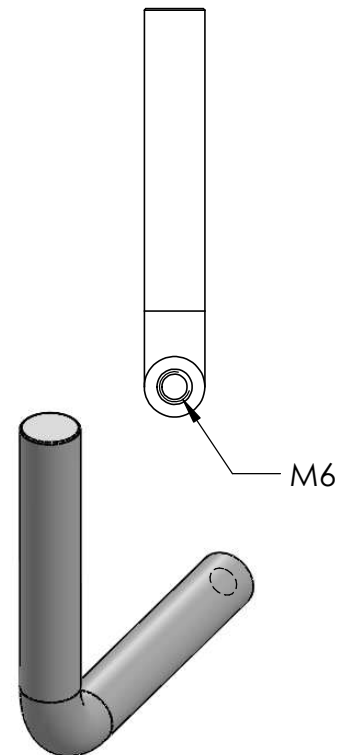
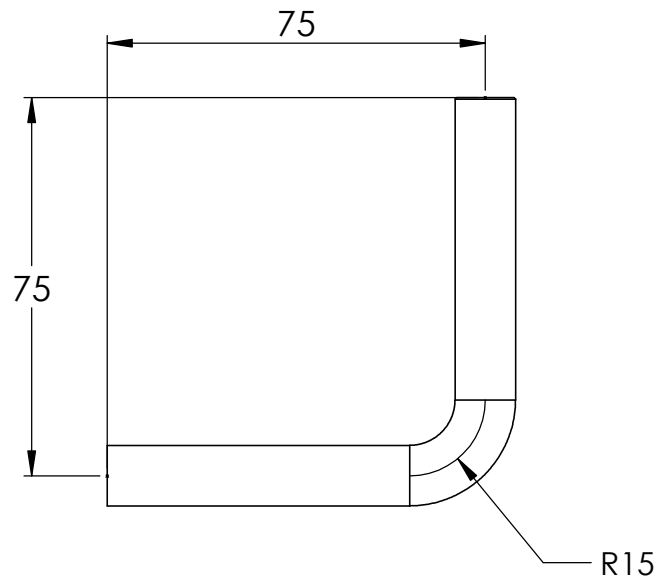
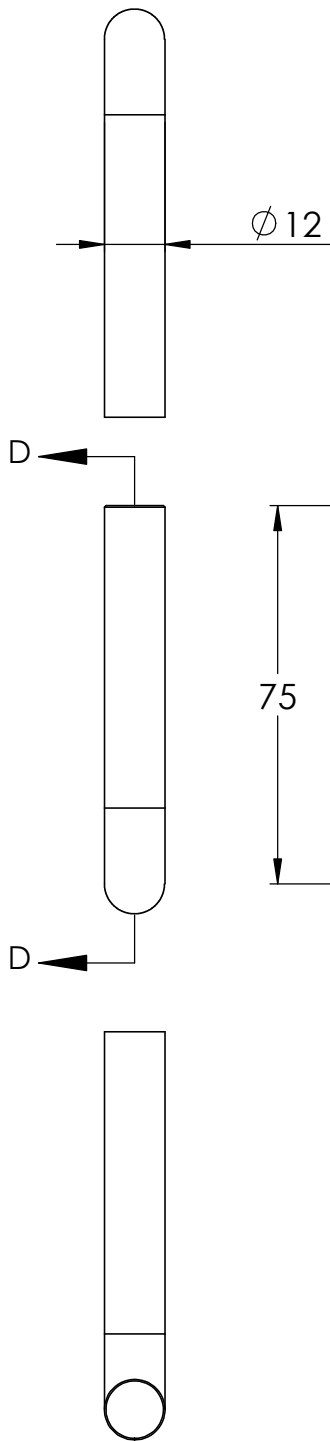
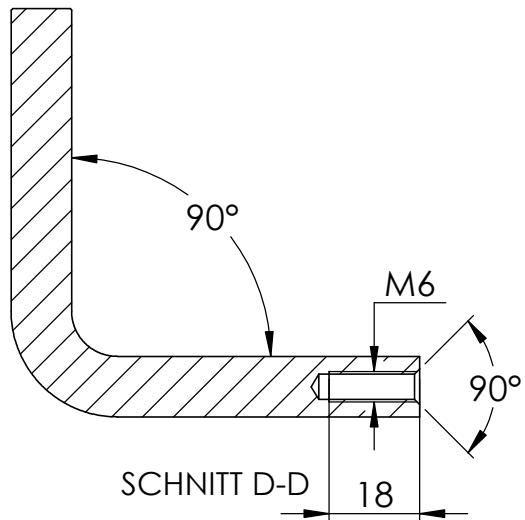

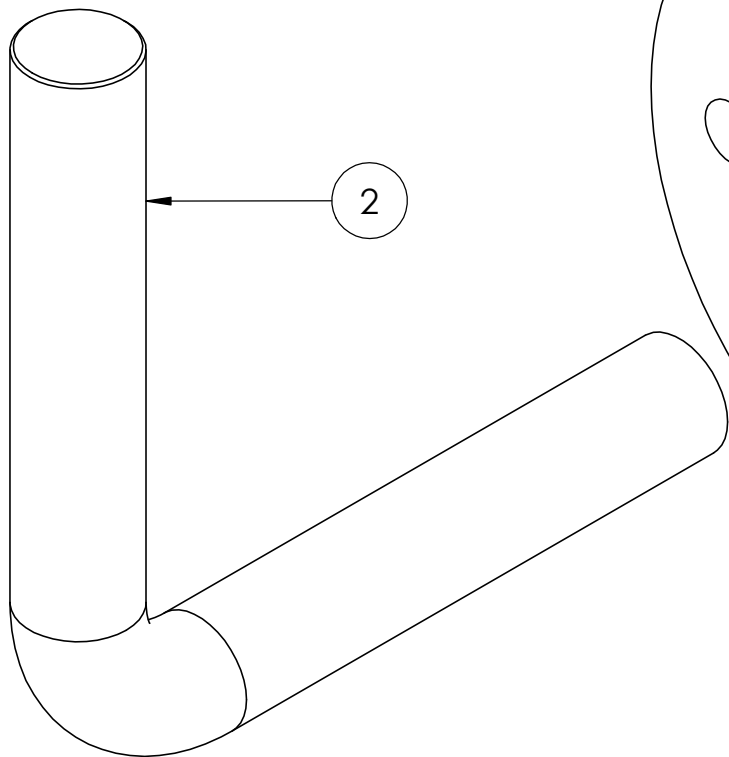

2



1

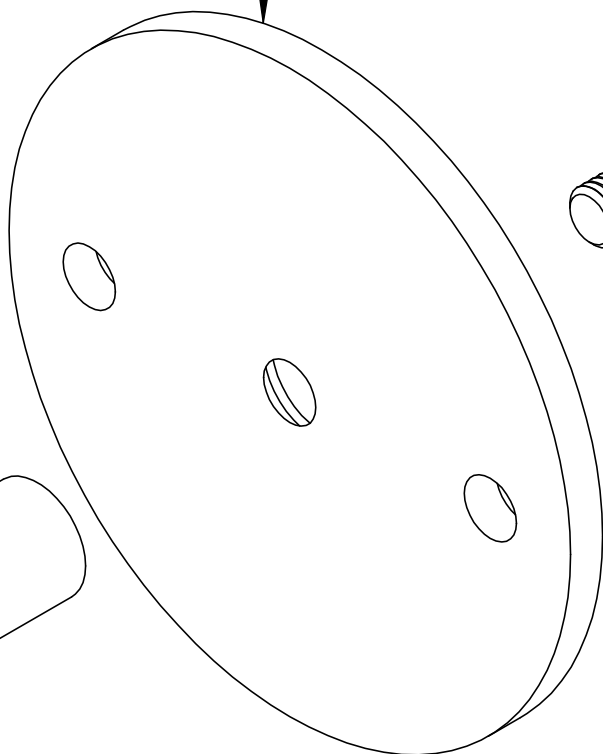

3

