

SCHNITT A-A

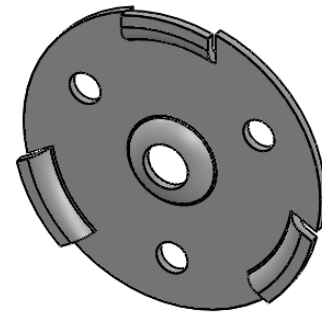

$\phi 12$

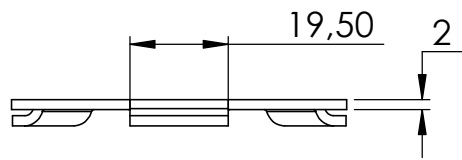
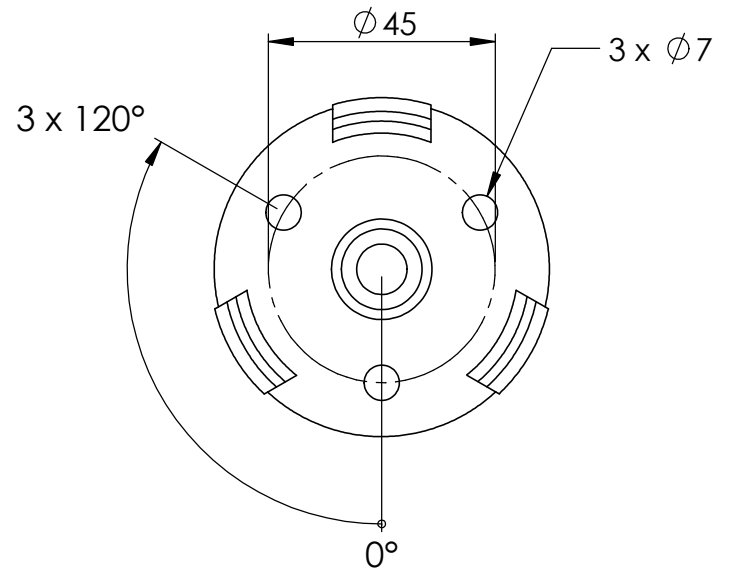
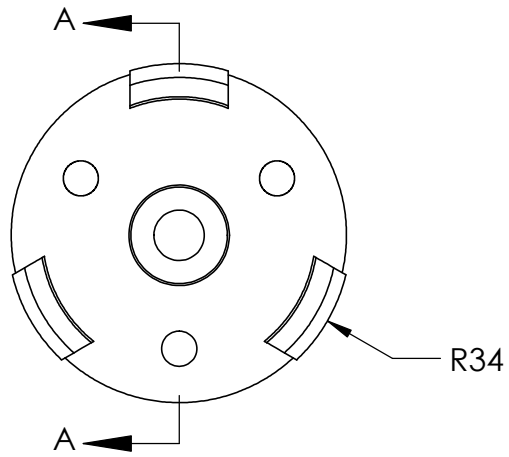
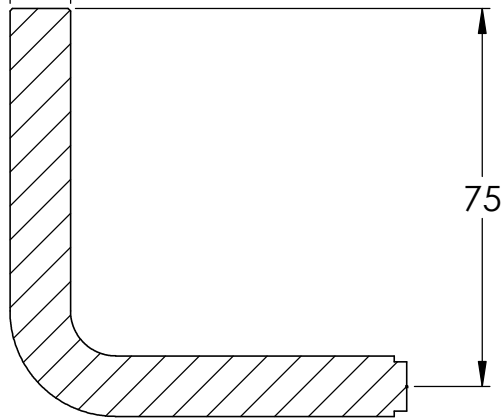

SCHNITT B-B

75

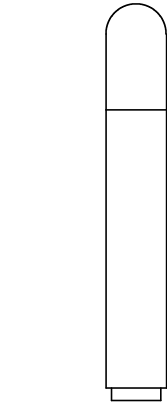

B

B

$\phi 9,80$

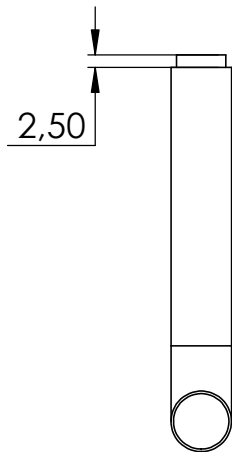

2,50

72,70

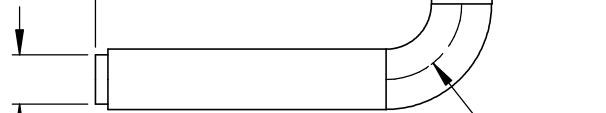

R15

0,50 X 45°

