

0,50 X 45°

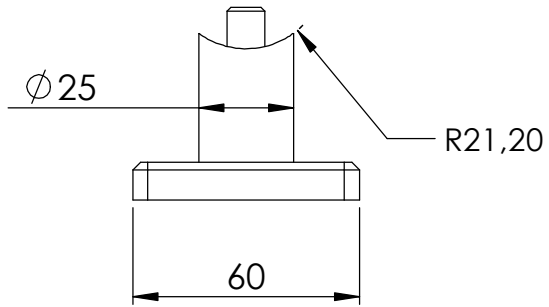

A ←

2 X 45°

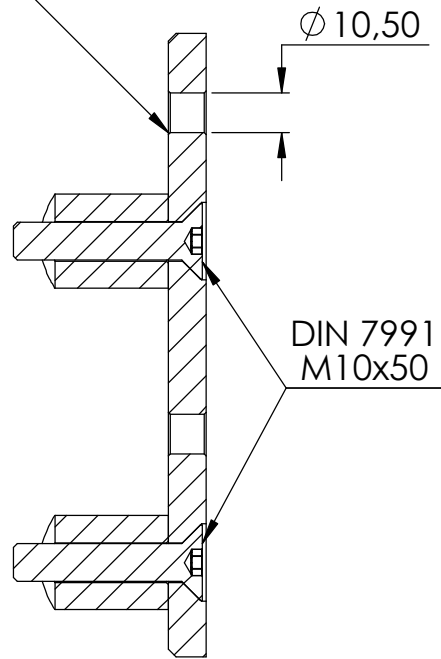
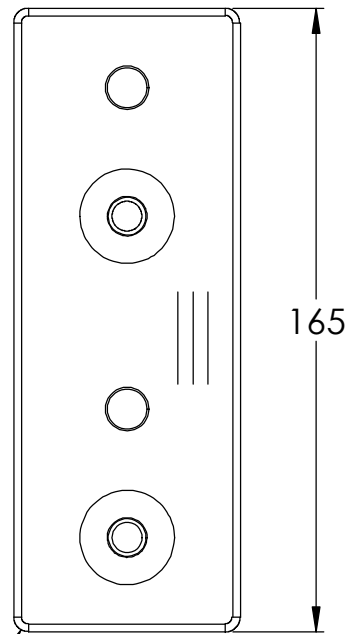

10^{+0,10}
-0,30

