

4 x M8 Gewinde (180° versetzt)

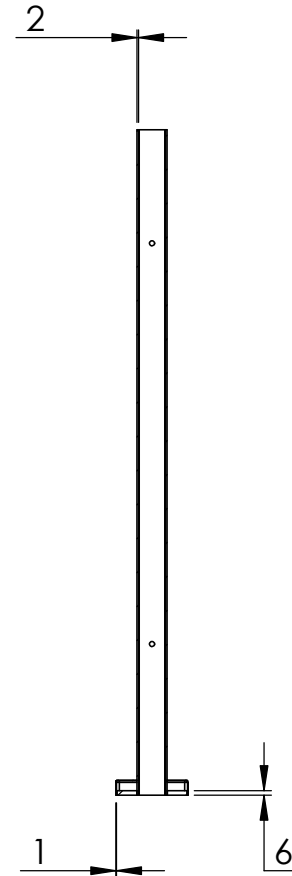

SCHNITT A-A

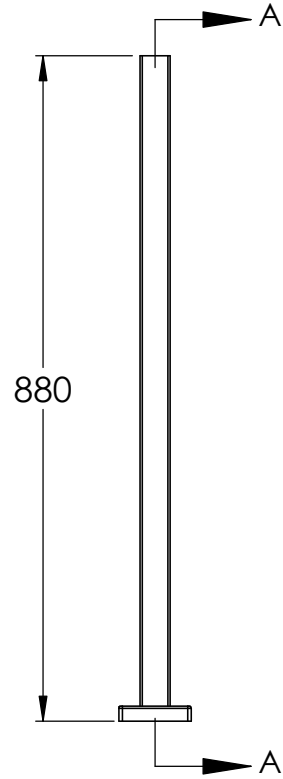

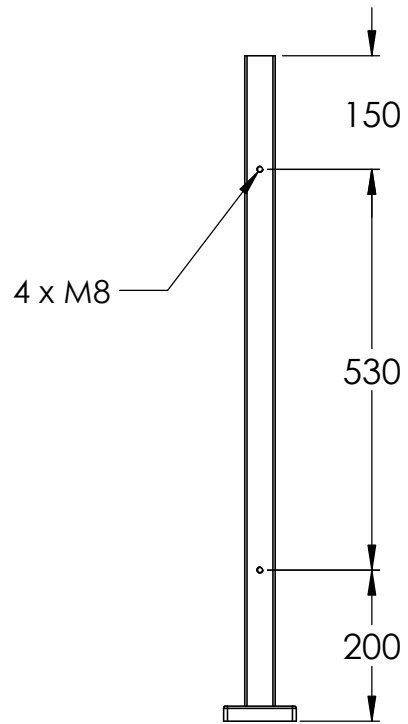
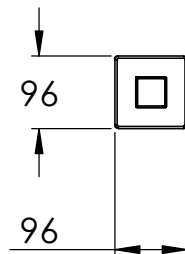
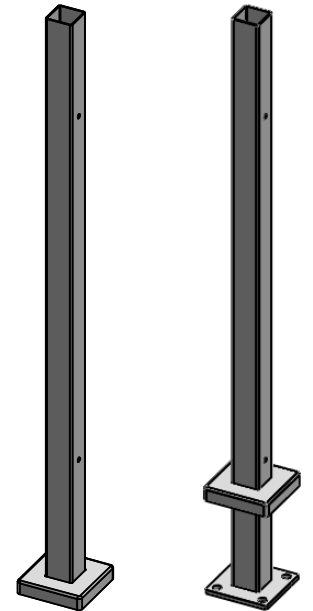
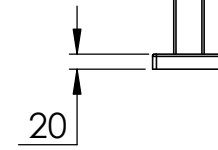

4 x M8 Gewinde (180° versetzt)

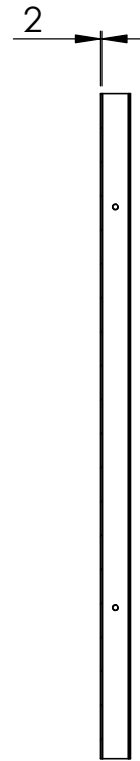
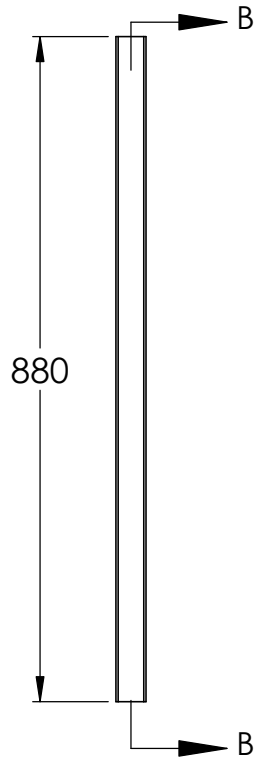
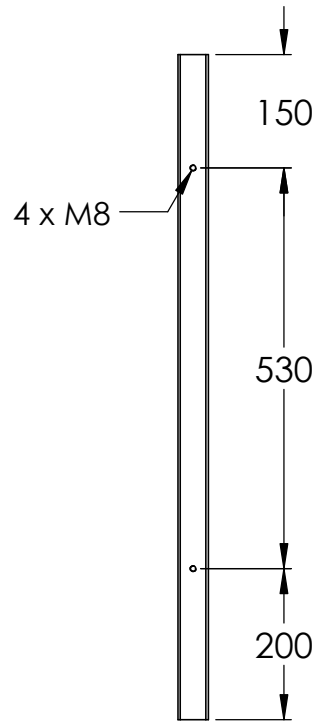

SCHNITT B-B

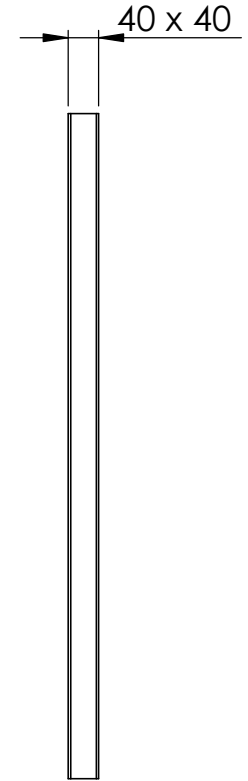

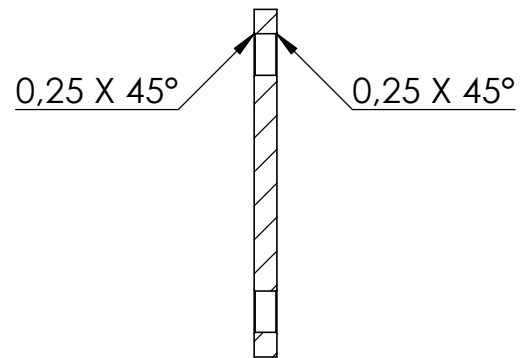
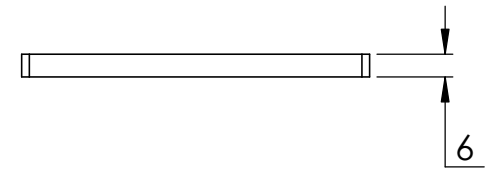
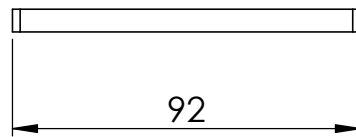
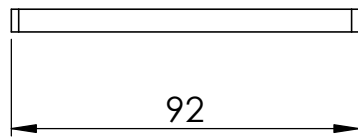
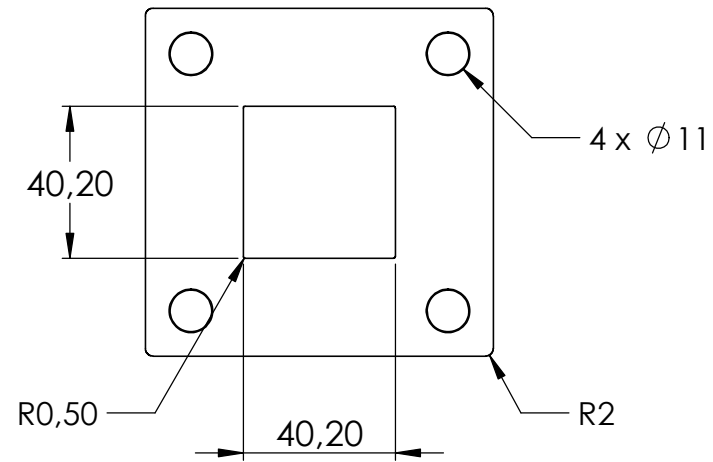

SCHNITT C-C

