

DIN 913
M12x10

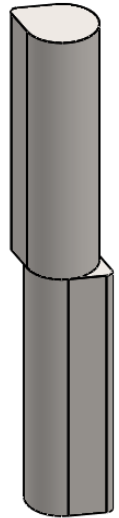

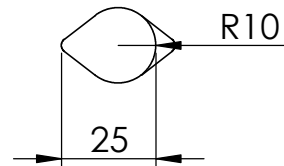

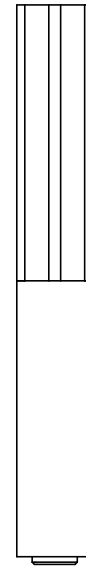

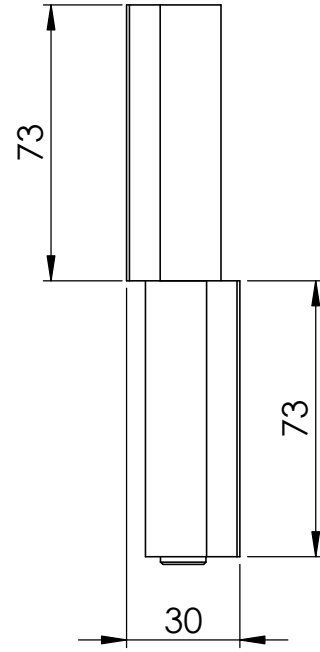
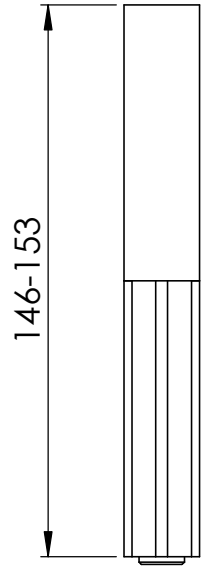
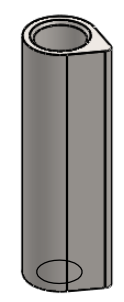
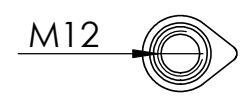
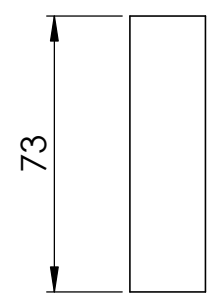
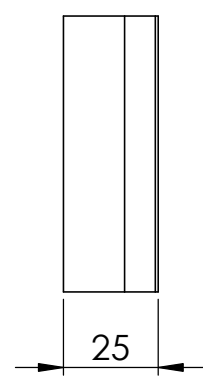
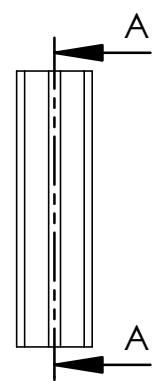
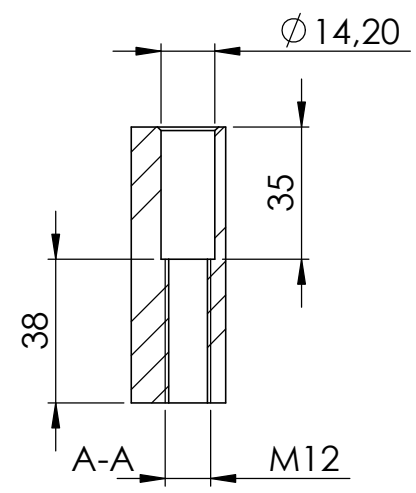
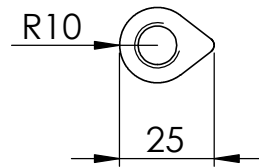
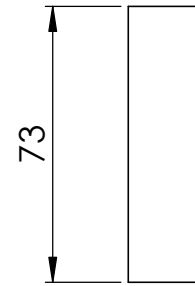
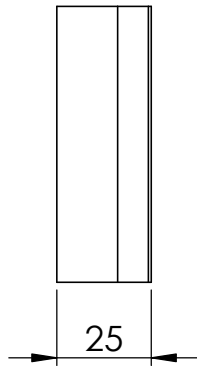
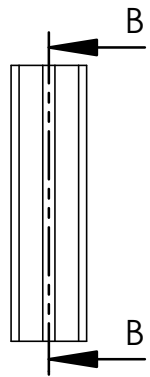
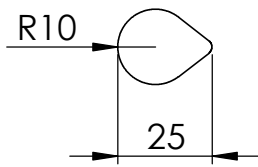
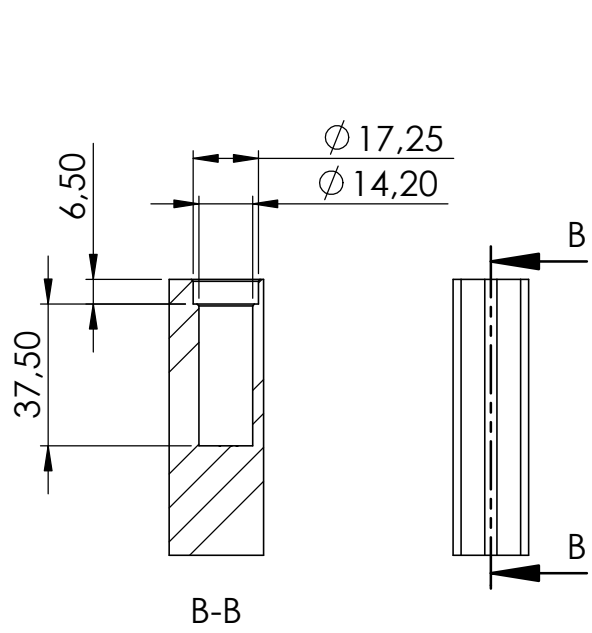
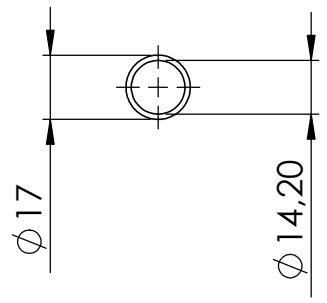
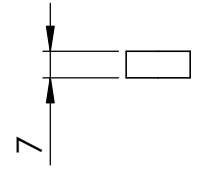

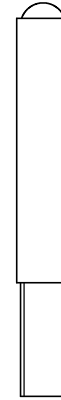
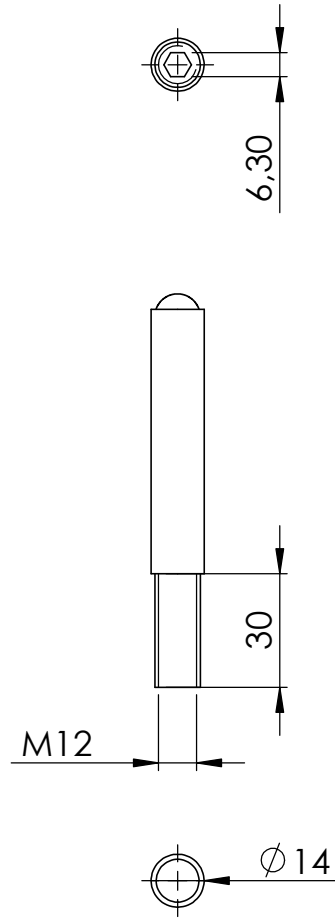
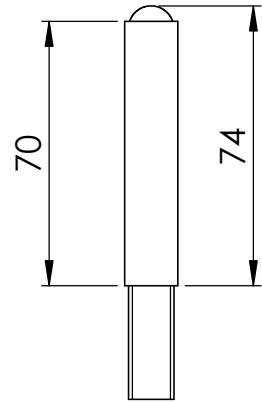

4	500-150 Teil4	1
5	DIN913 M12x12	1

