

DIN 7991
M10x65

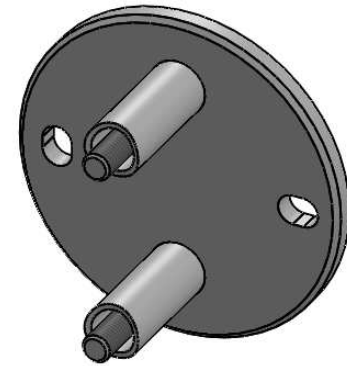

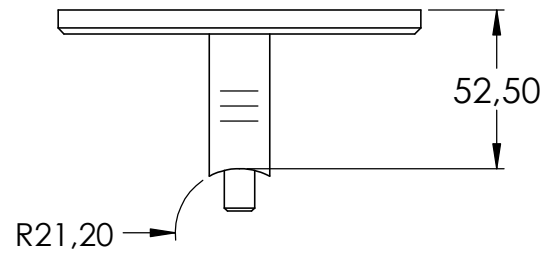

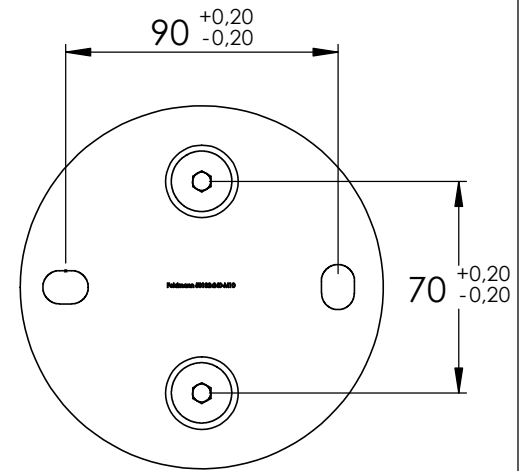

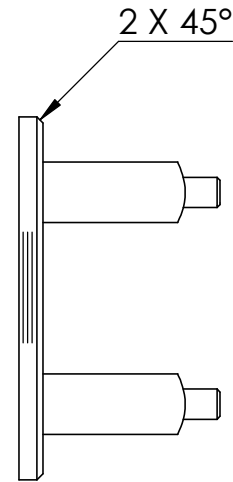
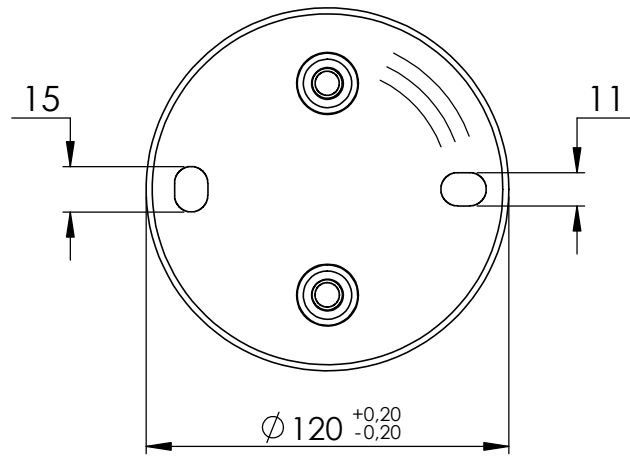
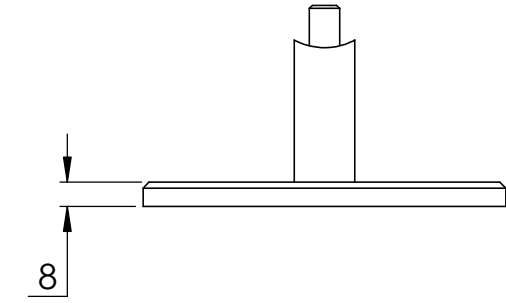
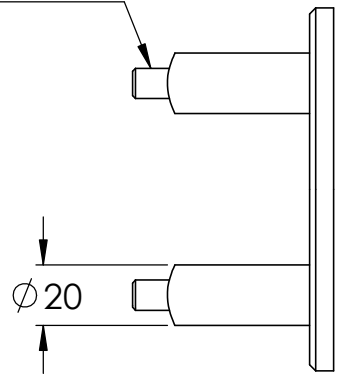
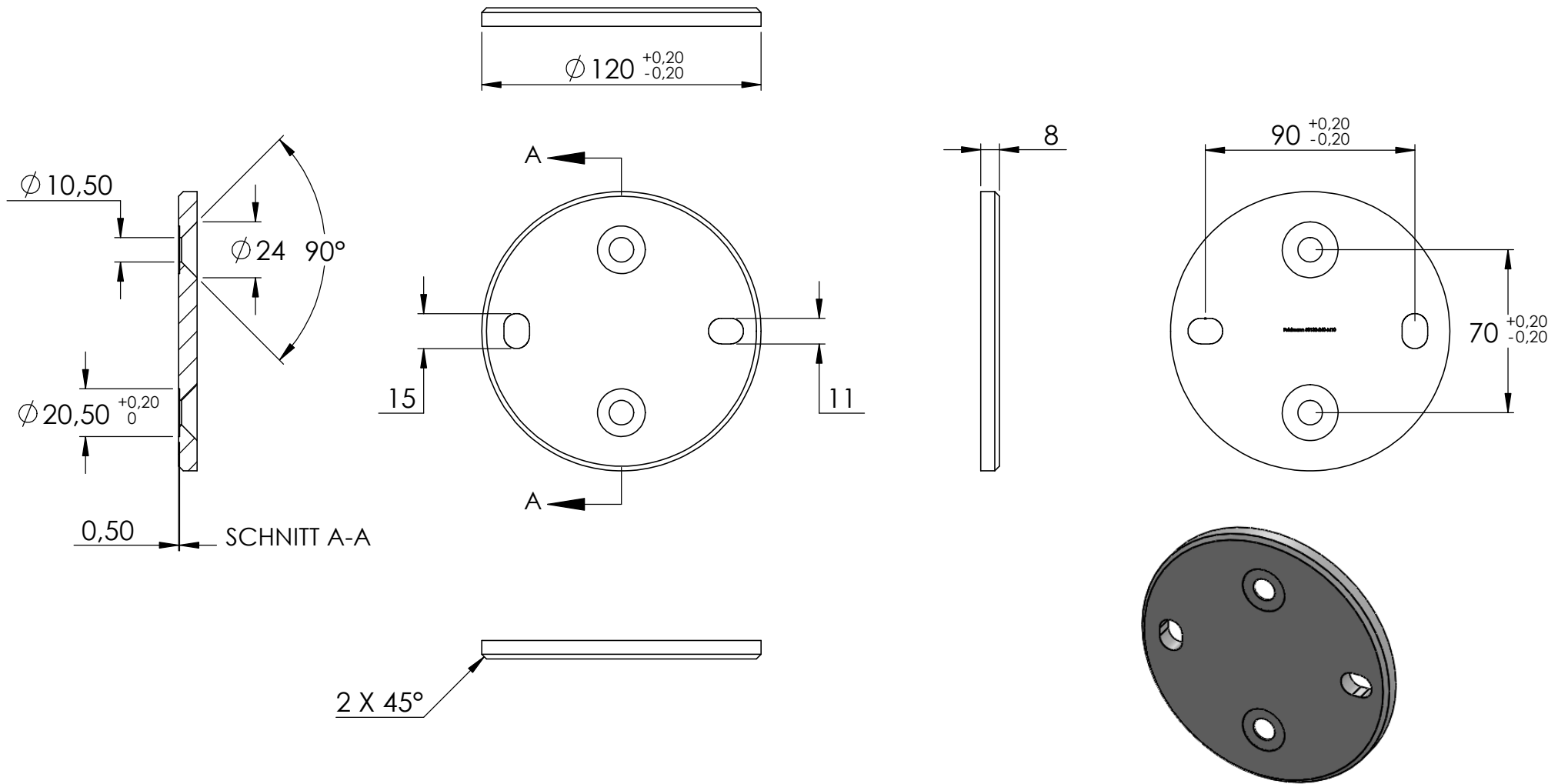
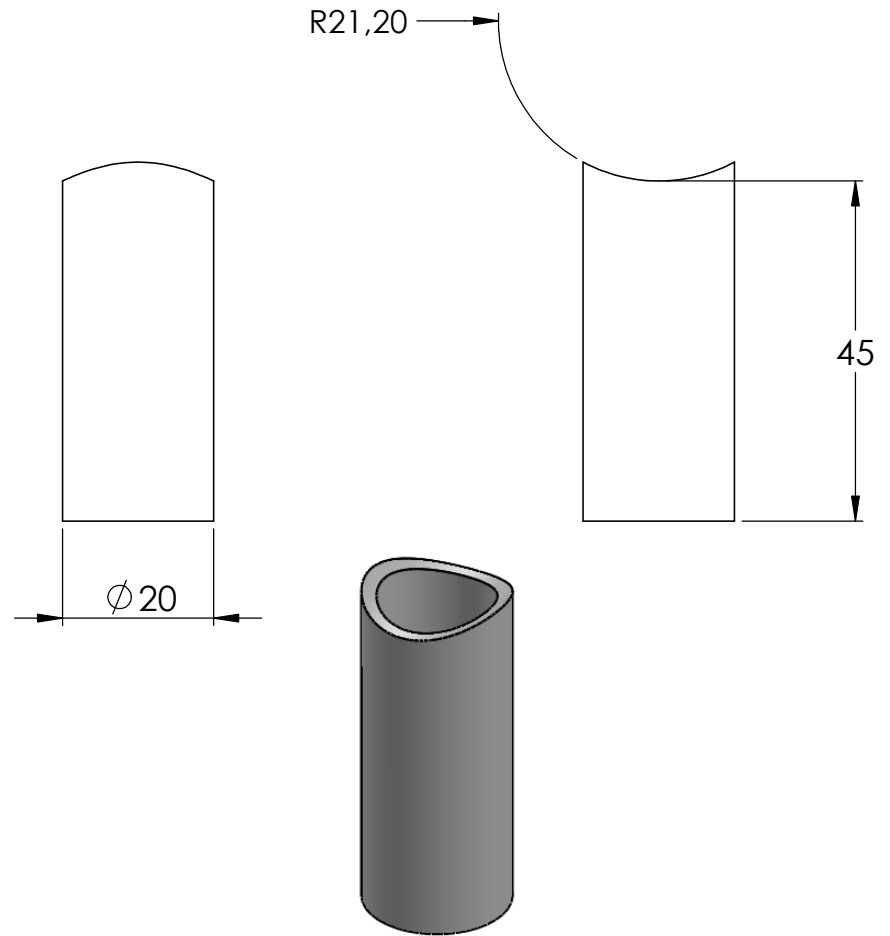
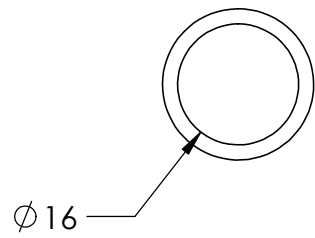
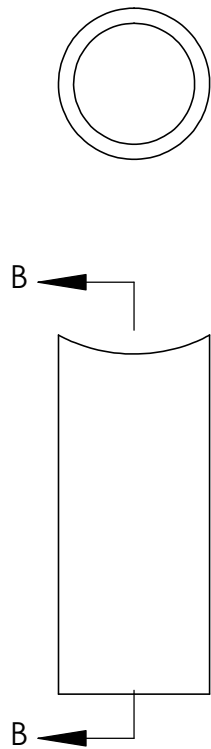
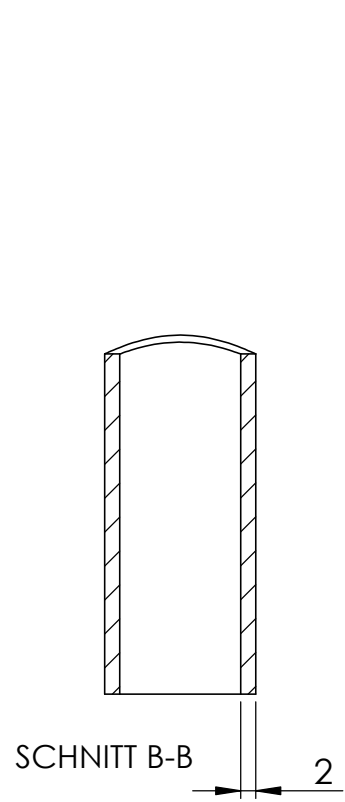
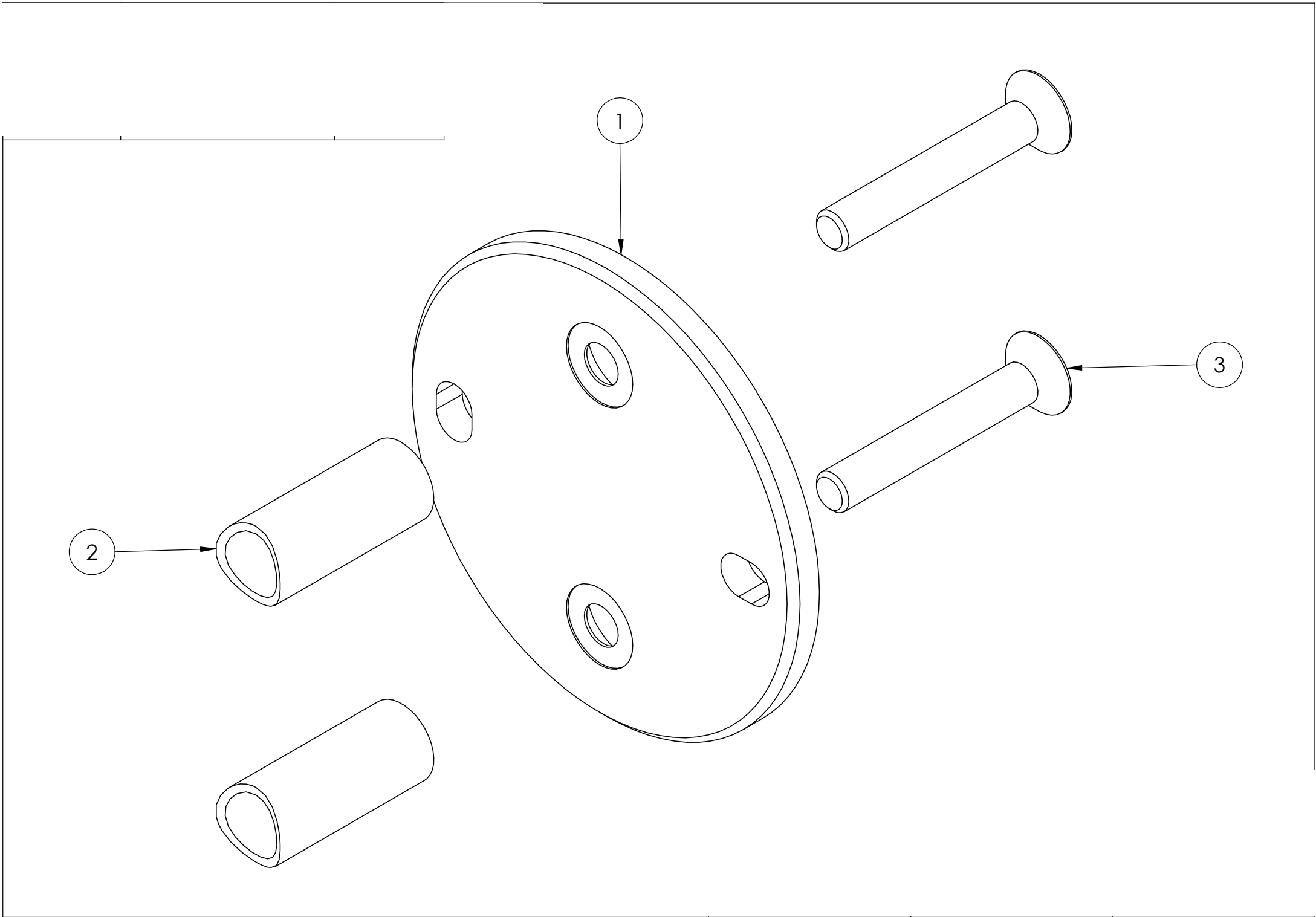

1

2

3