

C (3 : 1)

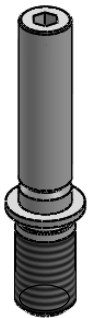

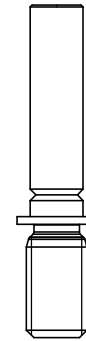

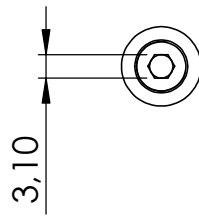
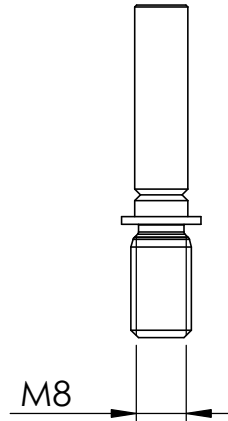
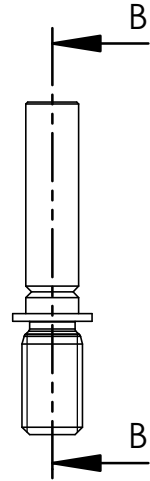
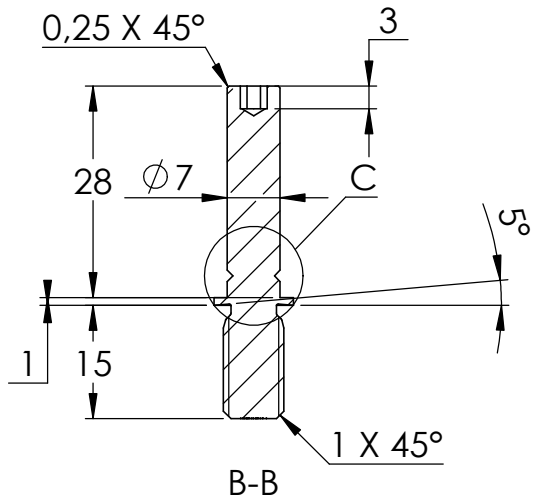
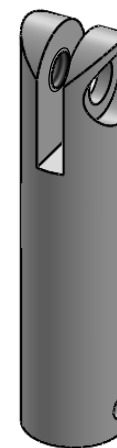
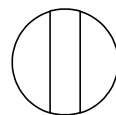
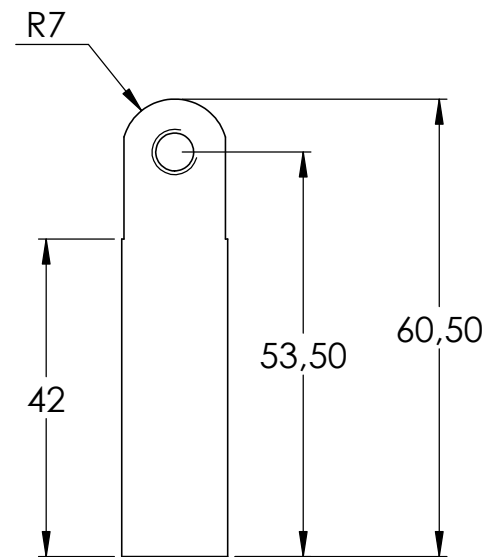
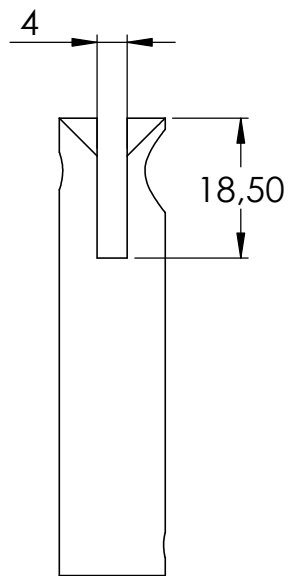
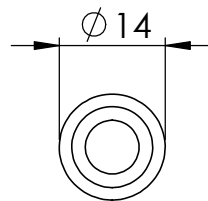
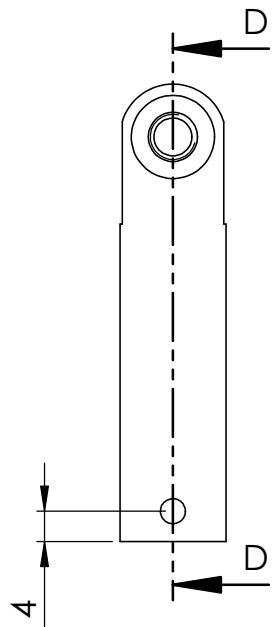
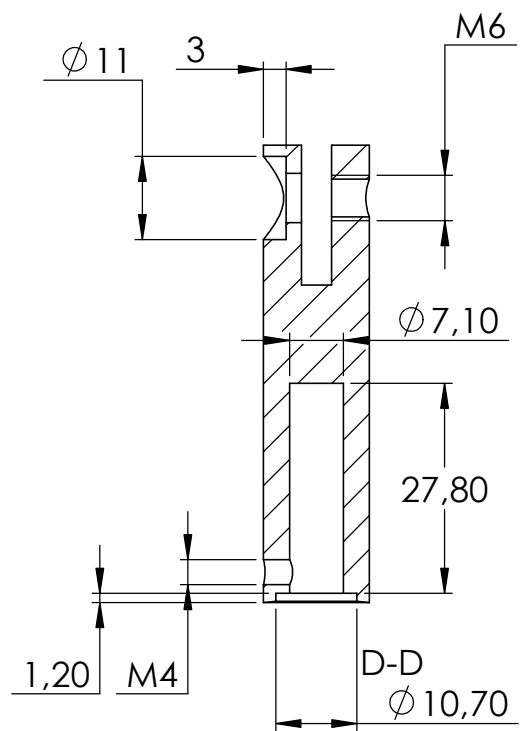
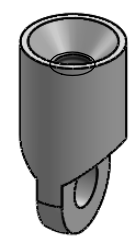
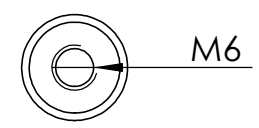
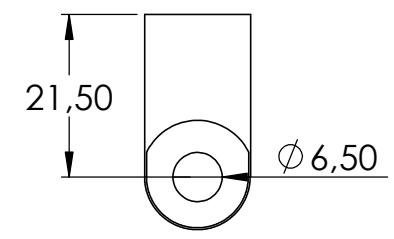
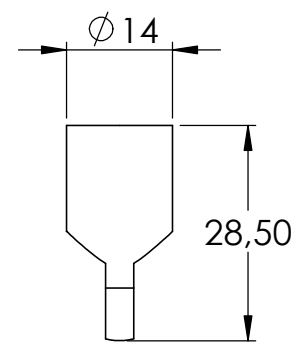
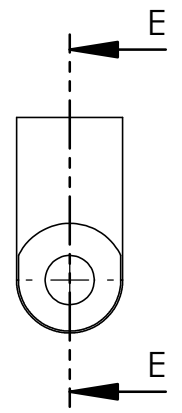
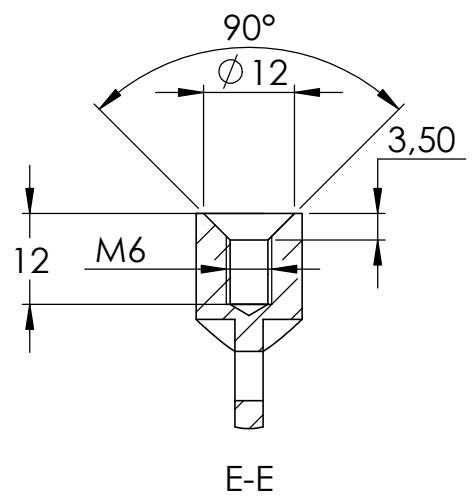
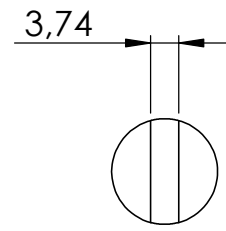

4	ISO 7380 M6x10	1
5	DIN 914 M4x4	1

