

SCHNITT B-B

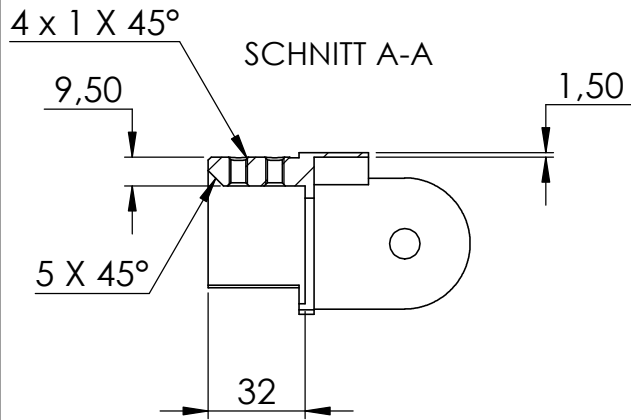

SCHNITT A-A

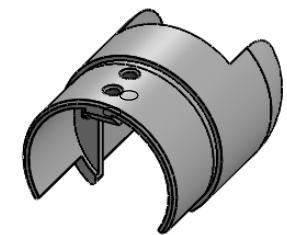

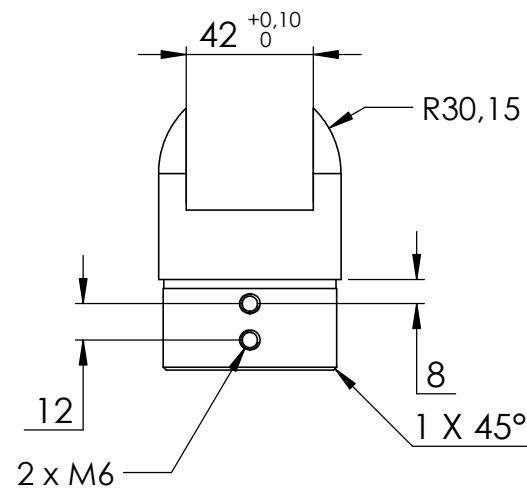
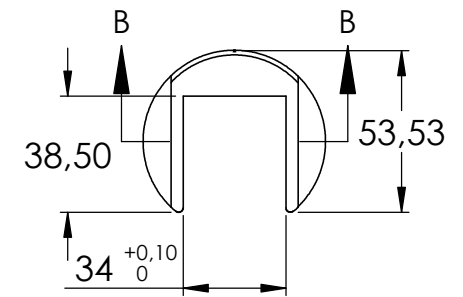
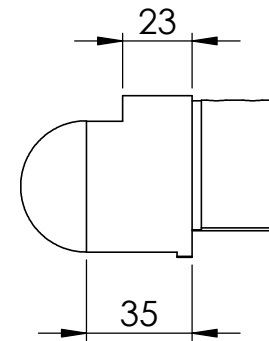
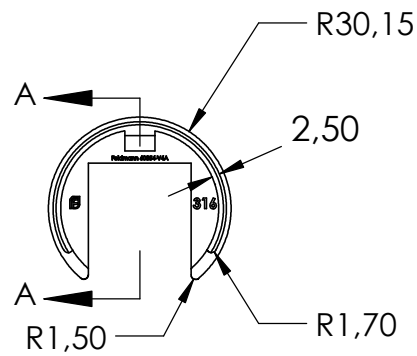
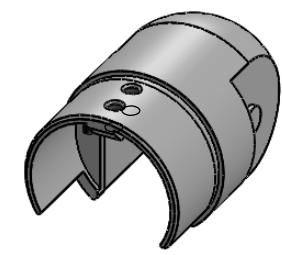
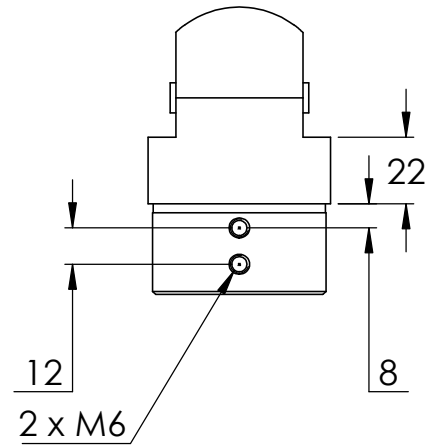
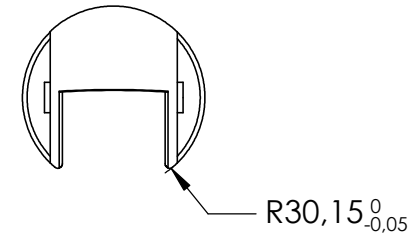
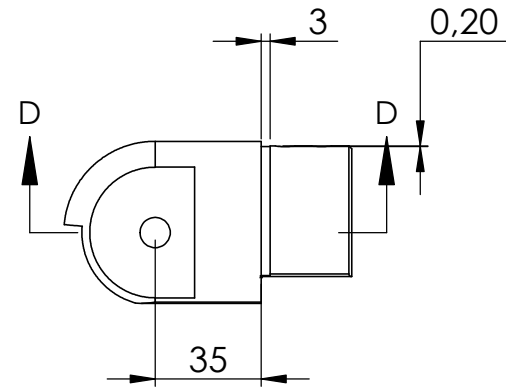
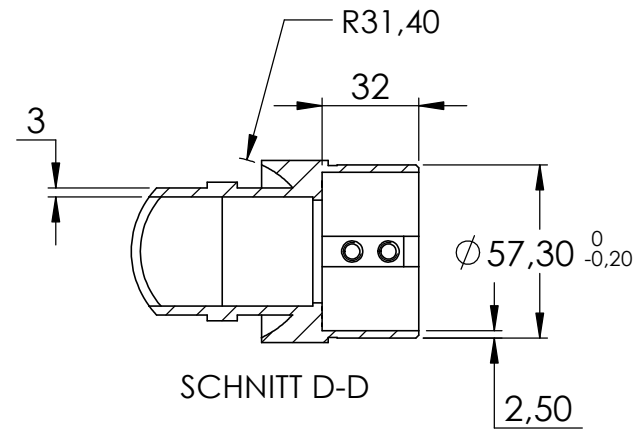
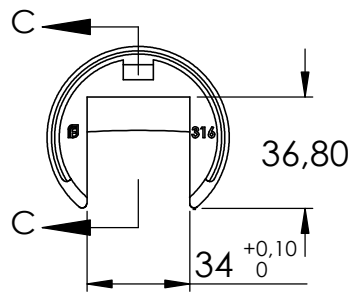
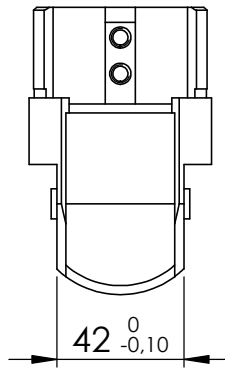
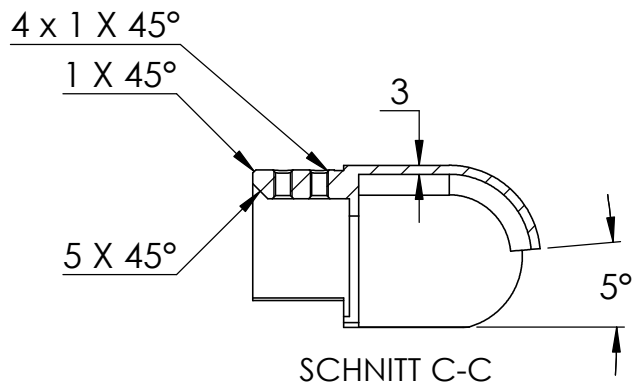

25°

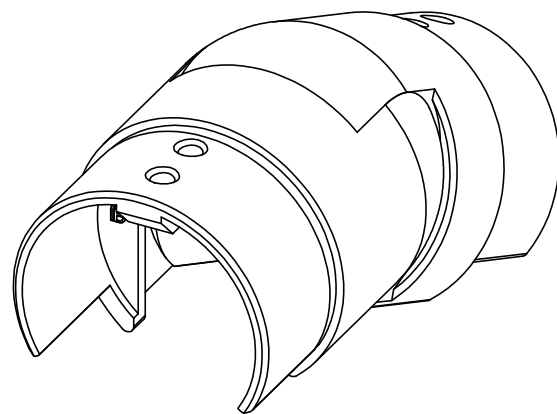

55°

