

Ø 12,50

M8

7

R2

60,24

39,74

3°

3

1

3,50

Ø 4,20

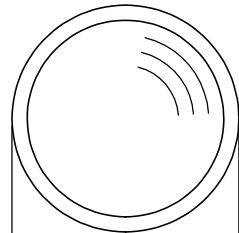

Ø 30

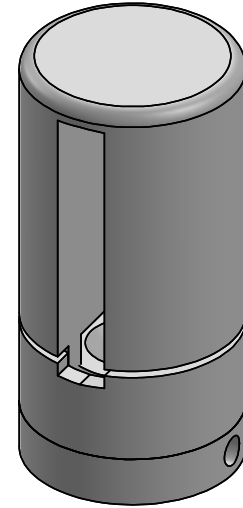

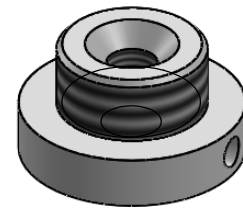
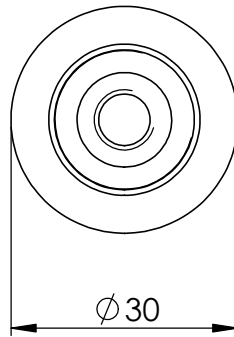
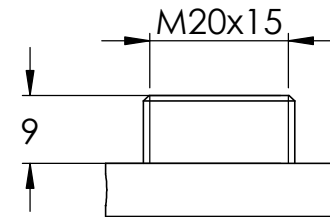
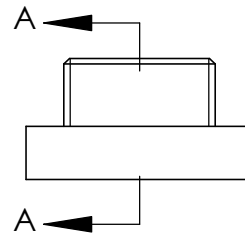
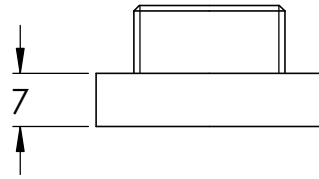
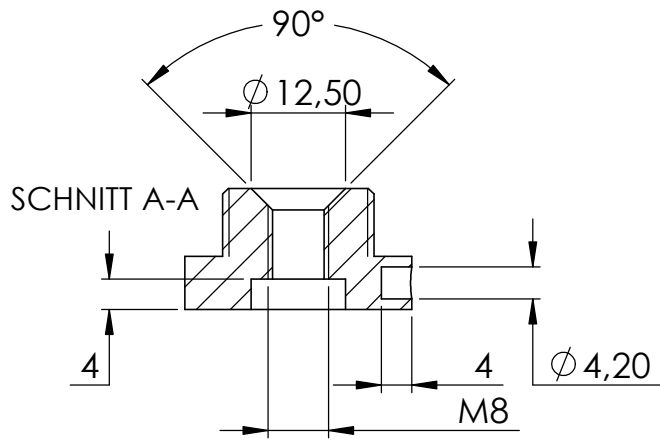
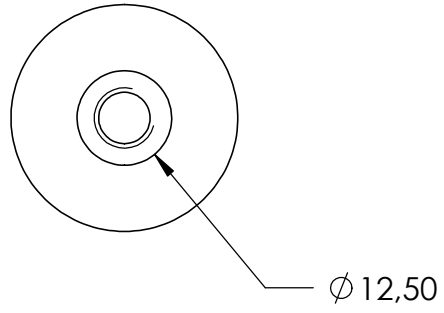

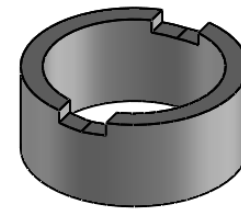
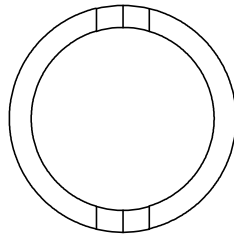
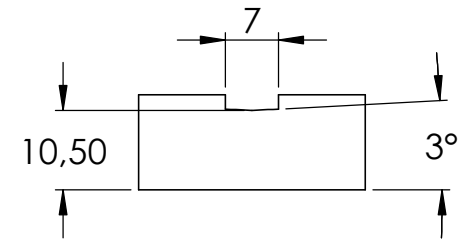
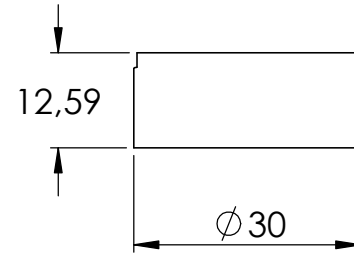
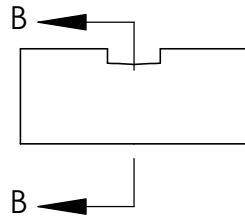
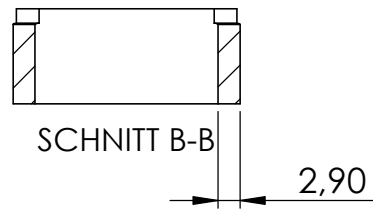
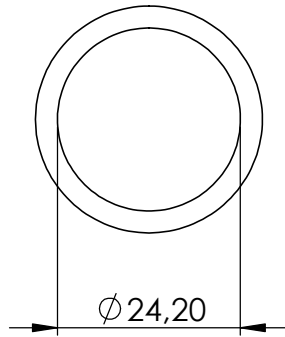

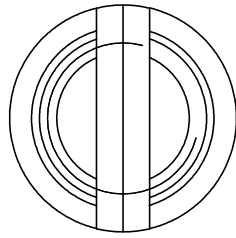

SCHNITT C-C

