

$\phi 12,50$

M8

11

R2

3°

3

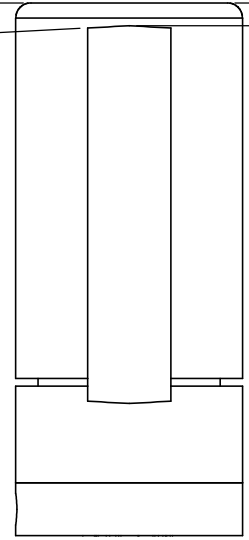
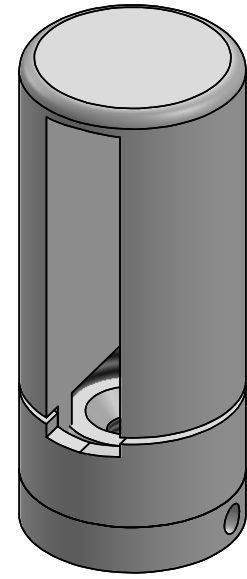
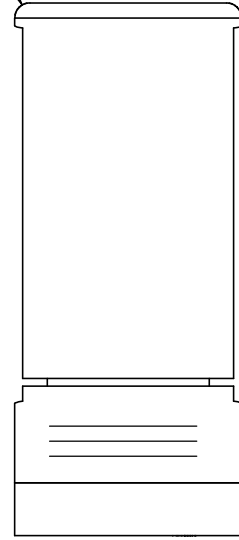
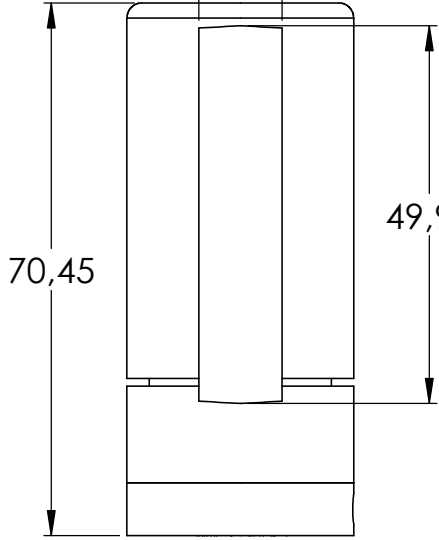
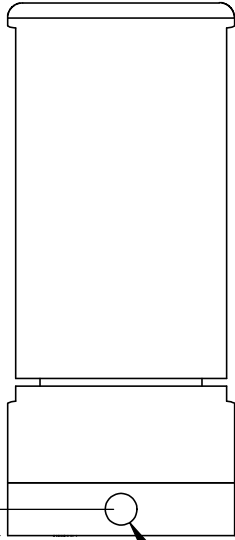

3,50

$\phi 4,20$

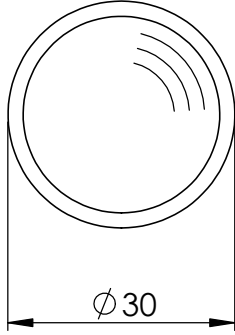

$\phi 30$

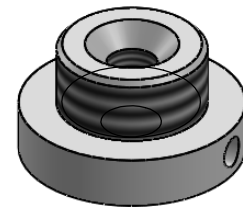
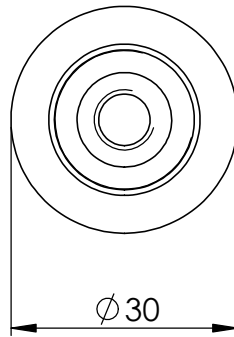
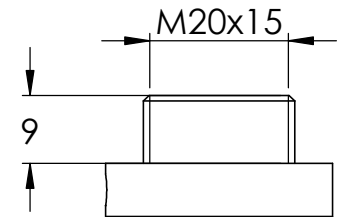
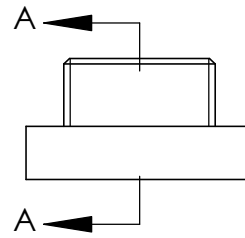
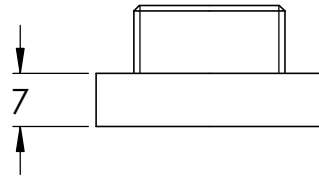
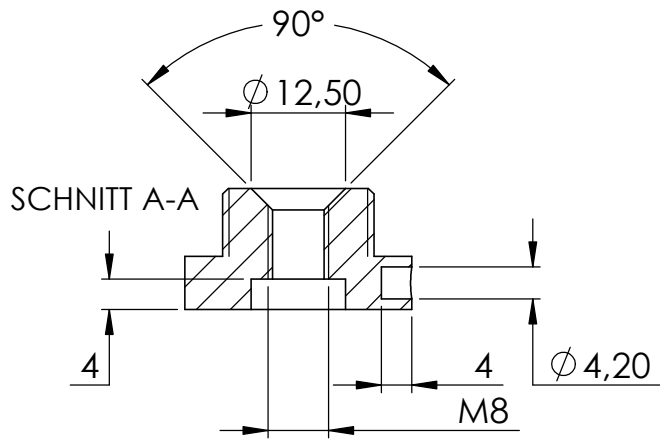
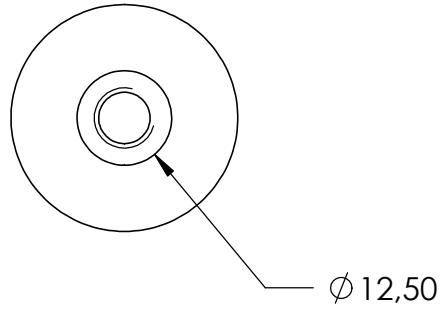

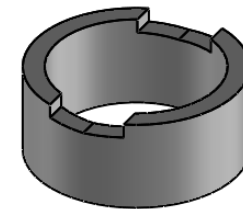
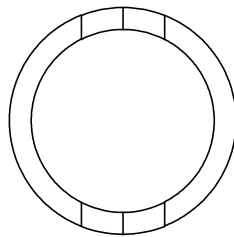
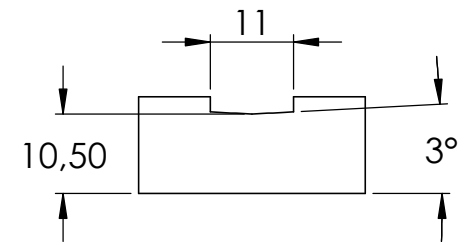
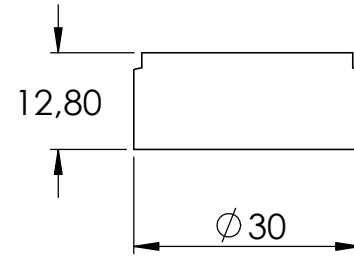
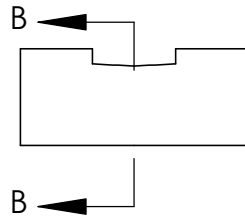
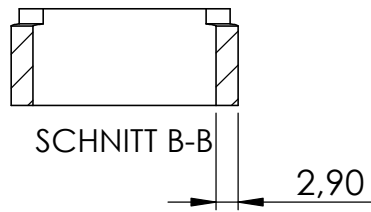
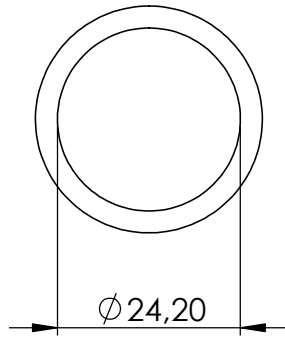

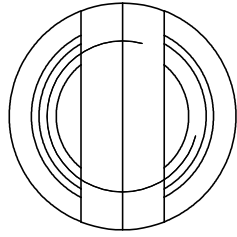

SCHNITT C-C

