

Ø 12,50

M8

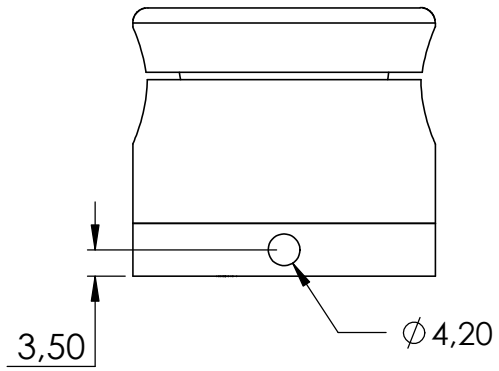

3,50

Ø 4,20

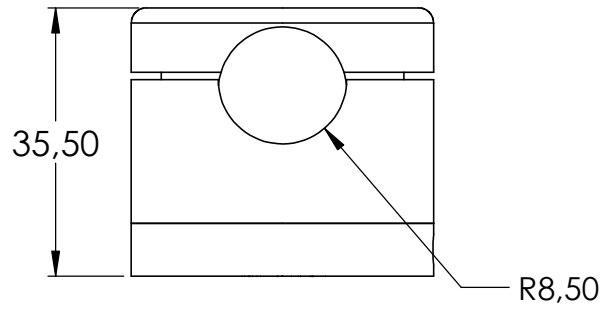

35,50

R8,50

R2

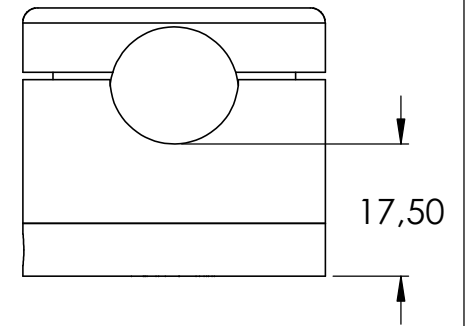
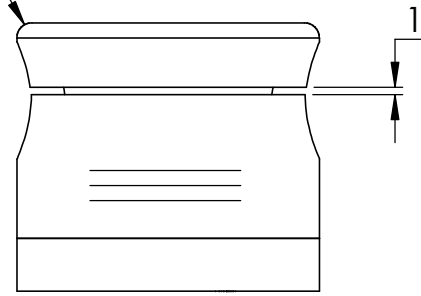

17,50

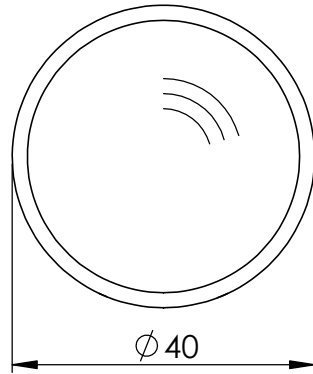

Ø 40

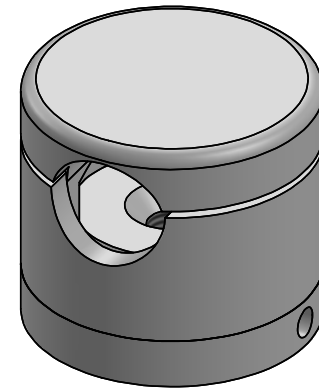

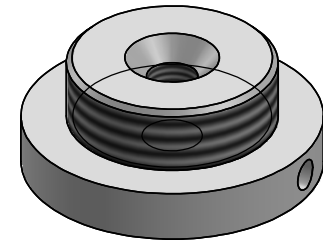
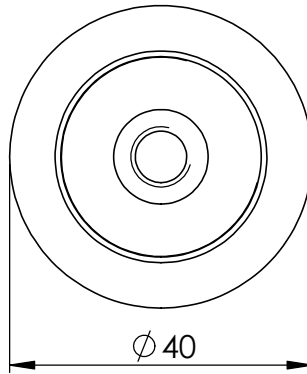
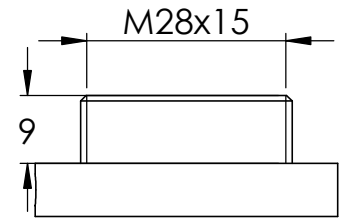
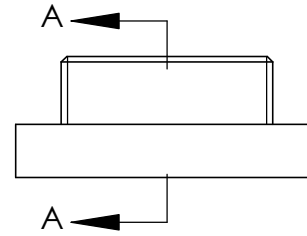
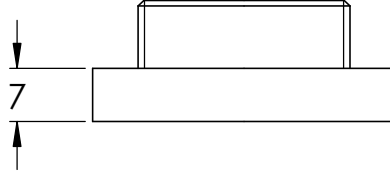
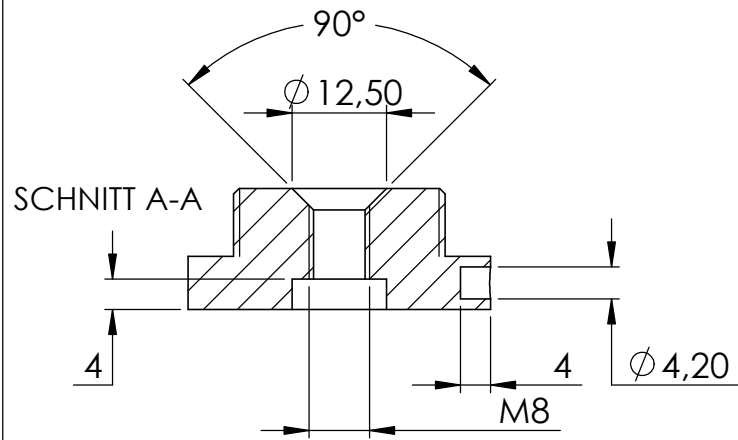
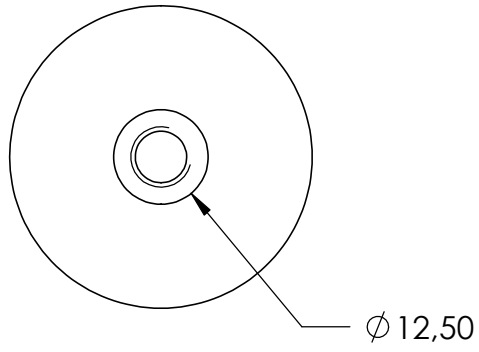

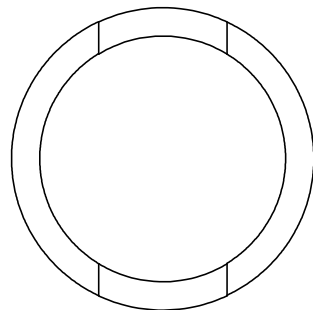
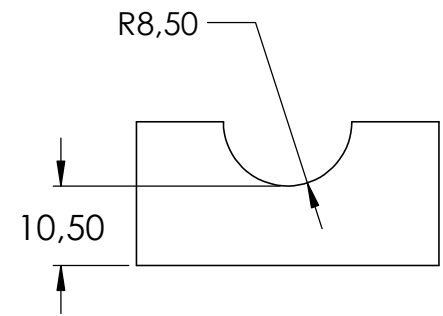
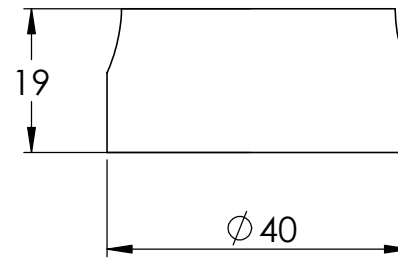
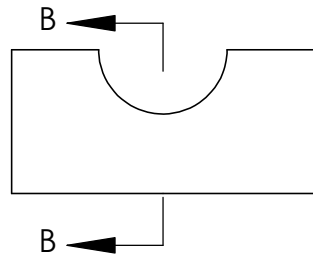
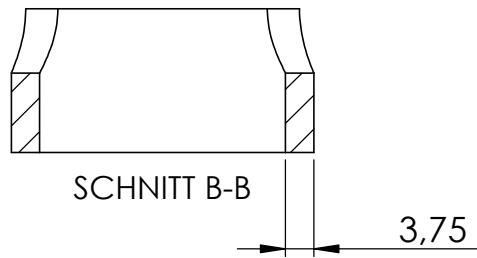
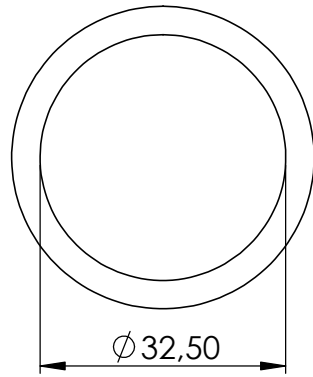

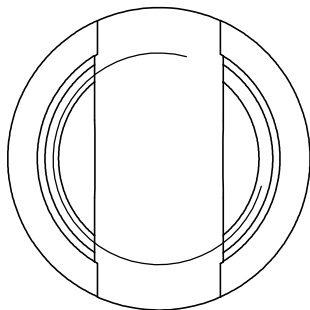

SCHNITT C-C

